

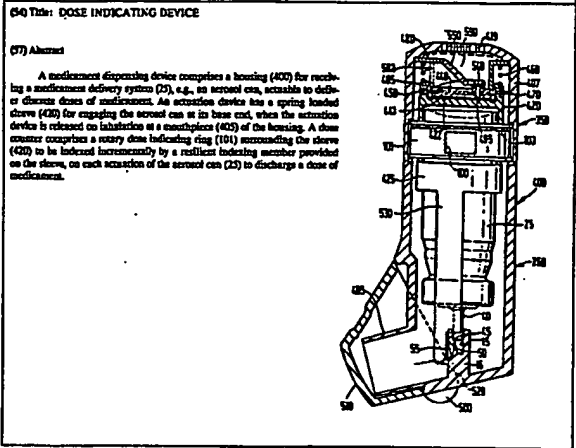

INTERNATIONAL APPLICATION PUBLISHED UNDER THE PATENT COOPERATION TREATY (PCT)

(5) International Patent Classification: A61M 15/00	A1	(11) International Publication Number: WO 93/24167
		(12) International Publication Date: 9 December 1993 (93.1257)
(3) International Application Number: PCT/GB93/01064	(8) Designated States: AT, AU, BA, BG, BR, BY, CA, CH, CZ, DE, DK, ES, FI, GB, GR, HU, JP, KP, KR, KZ, LI, LU, MG, MN, MW, NL, NO, NZ, PL, PT, RO, RU, SD, SE, SK, UA, US, VN, European patent (AT, BE, CH, DE, DK, ES, FI, GB, GR, HU, IT, LI, MC, NL, PL, SE, OA) patent (BF, BI, CF, CG, CI, CM, GA, GN, ML, MR, NE, SN, TD, TG).	
(2) International Filing Date: 24 May 1993 (24.05.93)		
(9) Priority data: GB 92143A3 29 May 1992 (29.05.92)	GB	
(7) Applicant (for all designated States except US): NORTON HEALTHCARE LIMITED (GB/GB); Central House, Fitz Meadow, Harlow, Essex, CM19 3TS (GB).	Published With international search report	
(7) Inventor: (7) Inventor/Applicant (for US only): HOLROYD, Michael, John (GB/GB); 1 The Green, Thripston, Repton, Nottingham NG8 7QX (GB).		
(7) Agent: BEN-NATHAN, Lawrence, Albert; Urquhart-Dykes & Lord, 91 Whitcomb Street, London W1M 5AH (GB).		



FOR THE PURPOSES OF INFORMATION ONLY

Codes used to identify States party to the PCT on the front pages of pamphlets publishing international applications under the PCT.

AT Austria	FR France	NO Norway
AU Australia	GB Great Britain	NP Nepal
BE Belgium	GR Greece	PL Poland
BR Brazil	IE Ireland	PT Portugal
CA Canada	IT Italy	RO Romania
CH Switzerland	JP Japan	RU Russian Federation
CL Chile	KR Korea	SE Sweden
CN China	LV Latvia	SI Slovenia
CO Colombia	MC Monaco	SK Slovakia
CZ Czech Republic	MD Moldova	UA Ukraine
DE Germany	ME Montenegro	US United States of America
DK Denmark	MG Madagascar	VE Venezuela
EE Estonia	ML Mali	VI Viet Nam
ES Spain	MM Myanmar	
FI Finland	MO Mozambique	
	NP Nepal	
	PE Peru	
	PH Philippines	
	PK Pakistan	
	PR Puerto Rico	
	RU Russian Federation	
	RO Romania	
	SE Sweden	
	SI Slovenia	
	SK Slovakia	
	UA Ukraine	
	US United States of America	
	VE Venezuela	
	VI Viet Nam	

DOSE INDICATING DEVICE

This invention relates to a dose indicating device for a dispensing device suitable for dispensing discrete amounts of fluid or particulate material entrained in an air stream.

Metered dose inhalers are well known in medicine for treatment, or alleviation of the effects of respiratory complaints, for example asthma. Breath-actuated devices are also known.

Aerosol dispensers provided with dose counting devices are also known. Some of these devices require substantial modification of the body part or housing of the dispenser to accommodate the counters or require additional containing structures. EP-0,197,113 provides a counter device which is mounted on top of the dispenser housing. US-4,817,822 utilizes a linear or rotary scale accommodated in a separate compartment outside to the dispenser housing. EP-0,258,238 utilizes a vertically disposed numbered wheel which projects upwardly of the dose metering device.

EP-0,269,494 describes a push button actuator for mounting on the neck of an aerosol dispenser, having a stroke counter comprising a counting ring with axially facing teeth which are engaged by an axially inclined flexible blade on the push button for actuating the aerosol valve.

GB-1,317,315; GB-1,390,484 and WO 92/09324 relate to counters for basic dispensers having an open ended housing in which aerosol cans are slidably mounted such that when the cans are manually depressed, a dose of medicament is released from the aerosol and inhaled through a mouthpiece at the opposite end of the housing. However, the counters are located beneath the cans and must be engaged by the lower, valve ends of the cans to cause the counters to index on each manual depression of the cans. Such arrangements have the disadvantages that modification of the housing geometry is

required at the critical area of the housing lower end where atomization takes place, the counter is accessible to a patient and could lead to misuse and its disposition could result in the inhalation of foreign matter if breakage of parts of the counter mechanism takes place.

Therefore, although several dose counting devices have been proposed the prior art devices are subject to many technical disadvantages.

It is an object of this invention to provide an improved dispensing device having actuating means, which may be breath actuated, capable of actuating a pressurized aerosol container or a dry powder drug delivery system, and a dose indicating means operated in association with the actuating means, the indicating means being relatively simple and convenient in structure and capable of being readily accommodated within the dispenser housing without substantial modification thereof as well as reducing the risks of incorrect actuation by a patient and of inhalation of small components which could become separated from the mechanism.

The invention provides a dispensing device for use with a medicament delivery system which can be actuated to deliver discrete doses of medicament, the dispensing device comprising a housing for receiving the medicament delivery system, the housing having an inhalation nozzle and a dose indicating device comprising an annular or arcuate dose indicating element rotatably mounted in the housing with a section of the indicating element being visible from outside the housing, and an indexing member movable on discharge of a dose of medicament to index the indicating element incrementally, characterized in that actuating means are provided in the housing for acting on an end of a medicament delivery system remote from said nozzle, to cause dispensing of doses of medicament; in that the indicating element is located in the housing around a part associated with the actuating means and in that the indexing member is carried by said part for movement in one axial direction through the indicating element on actuation of the medicament delivery system and in the

opposite axial direction for resetting the actuating means, with the indicating element being incrementally indexed on each movement of the indexing member in said one direction only.

Said actuating means are preferably breath-actuated on inhalation through the nozzle.

The indicating element may have internal teeth which are engaged by an indexing member which is resiliently mounted on the aforesaid part so that it can move inwardly of the teeth when it moves in said opposite direction, being the teeth and the engagement portion of said indexing member inclined with respect to the axis of rotation of the indicating element.

Preferably there may be provided means for restraining said actuating means, and means to release said restraining means. The release means are preferably breath actuated.

The actuation means may comprise means for applying a preload capable of actuating said drug delivery system.

The restraining means may comprise means for applying a resisting pneumatic force capable of preventing actuation of the actuation means. The pneumatic resisting means may be provided by a gas, e.g. air, which is either held at a positive pressure greater than atmospheric or a negative pressure below atmospheric prior to release. The release means will act to return the pressure to atmospheric or prior equilibrium, thus allowing the full force of the preload to act.

The means for applying a resisting pneumatic force may comprise an expandable gas tight chamber, the release means including valve means which can be opened to release a negative pressure prevailing in said low pressure chamber.

Although this device has been described in particular relation to a system using air, it will be realized that in a closed system any suitable gas could be used.

A device according to the invention is particularly suited for use with pressurized inhalation aerosols having valves which can be actuated to dispense a dose of medicament. However in other embodiments, a device according to the

invention can be used with a dry powder drug delivery system disposed within said housing, in which a dose of powdered medicament is dispensed by said system into an air flow in said housing created by inhalation at an outlet nozzle associated with the housing.

In some arrangements according to the invention for use with an aerosol dispensing container or a dry powder delivery system, the housing may include a slidable inner sleeve for enclosing the top portion of the main body of the aerosol container or the dry powder delivery system with the depending member being associated with the inner sleeve, with the indexing member being carried on the sleeve. This inner sleeve is preferably arranged to form one end of a gas tight piston cylinder, bellows or diaphragm, such that movement of the inner sleeve will result in an increase in the enclosed volume within the piston cylinder, bellows or diaphragm producing a vacuum or low pressure volume to form the resisting force capable of preventing the actuation of the drug delivery system.

A preferred breath-actuating release means comprises a movable vane mechanism. A valve seal is preferably attached to said vane, such that on inhalation the vane moves from its rest position closing said inlet means to its actuating position, thus moving the valve seal out of contact with the valve port, causing the opening of the valve to release the aforesaid resisting force. The vane mechanism is preferably dynamically balanced, and may be biased towards its closed position, e.g., by a spring.

Air inlets into the housing may take the form of slots in an upper end wall of said housing.

The medicament may be a drug per se or in any form of carrier, e.g., including a powder or a gaseous carrier.

Preferably the actuating means act on the aforesaid inner sleeve, and are reset by causing the inner sleeve member to move in said opposite direction.

Preferably a cover for an outlet nozzle of the housing is movably mounted on the housing, and a can formation on the

cover cooperates with the lower end of at least one depending member associated with the inner sleeve such that, when the cover is closed, the depending member moves the inner sleeve to reset the actuating means.

An embodiment of the invention will now be described by way of example and with reference to the accompanying drawings, in which:-

Figure 1 is a diagrammatic sectional view through a metered dose inhaler having a dose indicating mechanism in accordance with the present invention;

Figures 2A, 2B and 2C are sectional details of the inhaler showing the diaphragm in the pre-actuated, cocked, and actuated states, respectively;

Figure 3 is a diagrammatic perspective view of the dose counting mechanism of Figure 1; and

Figure 4 is a diagrammatic perspective detail of parts of the mechanism of Figure 1.

Referring to Figure 1, an inhalation device consists of a main body 400 which is generally cylindrical in cross section, with a mouthpiece section 403 at one end and an end cap section 407 housing air inlets 419 at the other end. A known type of aerosol dispensing container 25 of generally cylindrical shape is housed within the main body of the device. The aerosol dispensing container has a stem 40 which contains an aerosol dispensing valve (not shown). The bore 15 of a pedestal 16 in the housing, is such that it forms an airtight seal on the stem 40 of the aerosol dispensing container 25. A shoulder 45 limits and locates the position of the stem 40, which in turn locates the aerosol dispensing container 25 in position in the main body 400. A passage 30 extends from the bore 15, continuing from the shoulder 45 to interconnect with a dispensing nozzle 55.

The opposite end of the dispensing container is contained within a sleeve 420 of slightly smaller cross section to the main body 400. The longitudinal axis of both the sleeve 420 and main body 400 is generally coaxial. The sleeve is slidable within the inner wall of the main body to allow free

passage of air in the main body past the sleeve. The sleeve 420 may be held in place by connection with a diaphragm 440 held in connection with the top of the main body 400, as will now be described. Thus, the sleeve 420 effectively hangs from the top of the main body.

One end of an e.g., moulded flexible diaphragm 440 (as indicated in Figure 2C) comprising a rigid disc-like section 441, a flexible generally cylindrical wall section 445 and a stiffer annular connector flange 447. The sleeve 420 has a cooperating annular connection flange 450. An annular U-section clip 470 snaps over the flanges 447 and 450 to hold them together in an air-tight manner. A further lip 418 on the clip provides a snug fit for one end of a compression spring 460. The compression spring is thus located and free to act on the sleeve. The other end of the compression spring is located by an annular flange of a predominantly cylindrical flanged insert 480 housed in the top section of the main body 400. This insert includes a groove 485 into which the disc-like section 441 of the flexible diaphragm 440 is snap-fitted.

The shape of the top surface 422 of the closed end of the sleeve to conform to the internal shape of the diaphragm such that in the rest (preactuated) position of the inhaler (Figure 2A) the two surfaces are in close proximity, and the enclosed space between them very small.

The cylindrical insert 480 is retained in place by the end cap 407 comprising the upper part of the main body 400 of the device. This forms a chamber 590 between the air inlet slots 419 and the rigid part 441 of the diaphragm. The chamber is provided with one or more air pathways 580 such that air may pass from the air inlet slots 419 to the mouthpiece 403. The rigid disc-like section 441 of the diaphragm also includes a small valve port 495 which is normally covered by a diaphragm valve seal 540 housed in a vane 550 pivotally connected to the insert 480.

The vane 550 in its rest position divides the chamber 590 between the air inlets 419 and the air pathways 580 that link to the mouthpiece such that it may move from its rest position

by means of a pressure drop between the air inlets and the mouthpiece. On movement of the vane to the actuated position (Figure 2C) the valve seal 540 is moved sufficiently to open the valve port 495. The vane 550 may be biased closed by a light spring flexure, a weight or a magnet not shown.

As shown in Figure 1, the lower end of the main body has a moulded section 500 beneath the mouthpiece 405 to which a dust cap is pivotally connected. A can 520 is integrally formed on each side of a dust cap 510, one on each side of the moulded section 500. An annular yoke member 425 is secured to the lower end of the sleeve 420 and has a pair of downwardly depending legs 530, the lower ends of which act on the cans 520 such that when the dust cap is in the closed position the inner sleeve is forced by the can follower to its uppermost position.

When the dust cap is rotated to its open position the can profile is such that the can follower is free to move downwards by an amount sufficient to allow actuation of the device.

In its rest position (Figure 2A) the dust cap 510 is closed, the legs 530 of the yoke member restrain the inner sleeve 420 in its uppermost position such that the enclosed space trapped between the diaphragm 440 and the top surface 422 of the inner sleeve is at a minimum and the spring 460 is compressed. The valve port 495 is closed by the valve seal 540 and the sleeve 420 is clear of the top of the aerosol can 25 which is thus unloaded.

The dust cap is opened rotating the integral can 520 allowing the can follower 530 to drop by an initial amount of downward movement. The inner sleeve is forced downwards under the action of the spring 460. As the inner sleeve moves downwards the enclosed volume between the diaphragm 440 and inner sleeve is increased. Since the valve port 495 is closed this creates a low pressure volume or near vacuum in the space 600 then defined between the upper surface 422 of the sleeve 420 and the diaphragm 440. The effect of the pressure differential between the enclosed volume 600 and atmospheric

pressure is such that the inner sleeve tends to resist the action of the spring 460. As the inner sleeve moves downwards it contacts the aerosol can 25 and begins compression of the aerosol valve (not shown).

Downward movement of the inner sleeve 420 will continue until there is a balance of forces between the compressive force in the spring 460 and resisting forces created by the pressure differential and compression of the aerosol valve. This represents the cocked position shown in Figure 2B. The geometry of the device is arranged such that this balance occurs before the aerosol valve has been sufficiently compressed to actuate it.

A typical aerosol requires about 20N force to actuate. The spring 460 should accordingly provide a greater force, preferably 10% to 50% greater.

It may also be possible to arrange for the balance of forces to take place before the inner sleeve has contacted the aerosol can, such that the spring force is balanced by the resisting force produced on the inner sleeve by virtue of the pressure differential.

On inhalation by the patient through the mouthpiece 405, a small pressure differential is created across the vane 550 which is pivoted towards one end. The pressure differential causes the vane to move from the rest position to the actuated position. The vane and design of the air passageway 580 in the chamber 590 are such that in the actuated position air can flow freely from the air inlets 419 to the patient.

The movement of the vane 550 causes the valve seal 540 to be moved out of a sealing position with the valve port 495. Opening the valve port allows air into the space defined between the diaphragm 440 and inner sleeve 420 such that the enclosed space reaches atmospheric pressure. This causes an imbalance of forces acting on the sleeve 420 and the container 25. The sleeve and the container are thus forced downwards (Figure 2C) by the spring 460 resulting in the release of a measured dose of medicament through the dispensing nozzle 55 and into the mouthpiece at the same time as the patient

breathes in. Thus the patient inhales air with a metered dose of medicament.

After the inhalation of the dose by the patient, the dust cap 510 is returned to its closed position. This rotates the can 520 and causes the legs 530 of the yoke 425 to be forced upwards. This in turn acts on the inner sleeve 420 moving it upwards to compress the spring 460 and to close the space between the diaphragm 440 and the inner sleeve top surface 422. This forces air out of that space, which escapes through the valve port 495 lifting the valve seal 540. Since the valve seal is only lightly biased to its closed position it presents little resistance to air flow out of the enclosed space. The aerosol can is free to return to the rest position under the action of its own aerosol valve spring.

In use the patient loads the aerosol dispensing container into the main body. The aerosol container may be loaded by forming the main body 400 in two separable parts 350,360, which are joined by a threaded coupling. When the upper part 350 of the main body 400 has been unscrewed, the aerosol can be inserted. The upper part 350 can then be replaced locating the inner sleeve 420 over the top end of the can, and the device is ready for use. As described previously, the device could be manufactured as a sealed unit.

The construction and operation of the inhalation device is also described in WO 92/09323, to which reference should be made for further details.

The inhalation device is provided with a dose indicating mechanism in accordance with the present invention. The upper part 407 of the main body 400 of the inhaler is formed with a viewing window 100 through which numbers or other dose indication markings provided on a rotary ring 101, can be viewed. The ring 101 is located in annular recess defined in the upper body part 407.

The ring 101 is formed at its upper end with a set of internal, axially inclined ratchet teeth 103.

The ring 101 is rotationally indexed, in the direction of the arrow in Figure 3, by a predetermined amount, each time a

dose is dispensed from the aerosol container 25. This is achieved by providing an indexing member 109 on the sleeve 420 to cooperate with the internal teeth 103 on the ring 101. The member 109 is made of a strip of a suitable resilient material, e.g., spring steel, and has a flat base portion 108 secured to the outer wall of the sleeve 420. The free edge of the strip is bent outwardly and shaped to form the indexing member 109 which is also inclined with respect to the axis of the ring 101. A rectangular portion 107 is cut out of the flexible arm portion connecting the indexing member 109 to the base portion 108 so the connection is made by upper and lower limbs 105,106. This construction produces a resilient support structure for the indexing member 109 which is torsionally relatively rigid but is relatively flexible along its length. In this way the indexing member can readily flex radially inwardly of the ring 101 during each return stroke, as described below.

The teeth 103 and the indexing face 110 of the member 109 are similarly inclined to the axis of the body part 400. When the sleeve 420 is moved downwardly sufficiently to dispense a dose from the aerosol container 25, the indexing member 109 moves to its lower position as shown in Figure 4, thereby causing the indexing ring 101 to index by a predetermined increment to change the dose number displayed in the window 100.

In practice, with the indexing member 109 at its uppermost position, there is a small amount of play between the member 109 and the tooth 103 with which it is engaged. This play is taken up over an initial movement of the sleeve 420 as the breath actuating means is set on opening the cover 510, as described above. This accounts for an initial stroke of about 1 mm of the movement of the indexing member 109.

When the device is triggered by inhalation at the mouthpiece 405 to dispense a dose of medicament, the indexing member 109 completes its stroke of about 4.5 mm. At the end of its stroke the indexing member 109, which has a height of about 8 mm, remains still engaged with the teeth 103, as

indicated in Figure 4. On the return stroke, the indexing member 109 first engages the next inclined tooth 103, and then resiliently rides over that tooth to engage in the gap behind that tooth, ready for the next indexing operation. The indexing member at the beginning of its stroke is engaged with the teeth 103, which have a depth of about 2 mm, over a distance of about 1.5 mm.

As the yoke 425 is lifted to reset the device, by closing the mouthpiece cover 510, the indexing member 109 flexes radially inwardly of the ratchet teeth 103 on the ring 101 until, in its upper position, it engages in the next notch defined between the teeth 103 ready for a subsequent indexing operation.

It will be appreciated that the dose indicating mechanism is only actuated when the inner sleeve 420 moves downwards sufficiently to cause a dose to be dispensed from the aerosol 25. Therefore merely opening the mouthpiece cover 510 to reach the cocked position (Figure 2B) will not cause the dose indicating mechanism to be indexed.

Moreover a gap 600' is formed in the set of teeth 103 so that after the maximum number of doses have been dispensed from the aerosol can 25 the indicating ring 101 is no longer indexed by the indexing member 109. At this point an "empty" indication could be shown in the window 100.

The device may also be provided with a means such that it will not operate below a certain predetermined air flow rate, e.g., 10 to 30 litres per minute. In one embodiment the valve 550 will be biased by a spring such that the predetermined minimum air flow is necessary for it to move to its actuated position and enable the valve seal to open.

The main body of a dispensing device is preferably manufactured from a plastic such as polypropylene, acetal or moulded polystyrene. It may however be manufactured from metal or other suitable material.

so that it can move inwardly of the teeth (103) when moved in said opposite axial direction.

4. A dispensing device according to Claim 3 wherein a predetermined number of teeth (103) are provided so that said indexing member (109) disengages therefrom after a corresponding number of indexing operations of said indicating element (101) which then gives an empty indication on said section thereof visible from outside the housing.

5. A dispensing device according to Claim 3 wherein said indexing member (109) is carried by a connecting portion (105,106) which is attached to said part (420) and is resiliently biased towards said teeth (103).

6. A dispensing device according to Claim 5 wherein said connecting portion is made of a resilient material so as to bias the indexing member towards said teeth (103).

7. A dispensing device according to Claim 5 wherein said connecting portion comprises two spaced apart resilient, connecting limbs (105,106).

8. A dispensing device according to Claim 1 wherein said actuating means comprise a loading member (420) for engaging said end of the medicament delivery system (25), said indexing member (109) being carried by said loading member, means (460) to load said loading member (420) to actuate said medicament delivery system, means (440) to restrain said loading means (46), and means (550) to release said restraining means (440).

9. A dispensing device according to Claim 8 wherein said restraining means (440) comprise means for applying a resisting pneumatic force capable of preventing said loading means (460) from actuating the medicament delivery system (25).

CLAIMS

1. A dispensing device for use with a medicament delivery system (25) which can be actuated to deliver discrete doses of medicament, the dispensing device comprising a housing (400) for receiving the medicament delivery system (25), the housing having an inhalation nozzle (405) and a dose indicating device comprising an annular or arcuate dose indicating element (101) rotatably mounted in the housing (400) with a section of the indicating element being visible from outside the housing, and an indexing member (109) movable on discharge of a dose of medicament to index the indicating element (101) incrementally, characterized in that actuating means (420,440,460,550) are provided in the housing for acting on an end of a medicament delivery system (25) remote from said nozzle (405), to cause dispensing of doses of medicament; in that the indicating element (101) is located in the housing around a part (420) associated with the actuating means and in that the indexing member (109) is carried by said part (420) for movement in one axial direction through the indicating element (101) on actuation of the medicament delivery system and in the opposite axial direction for resetting the actuating means, with the indicating element being incrementally indexed on each movement of the indexing member (109) in said one direction only.

2. A dispensing device according to Claim 1 wherein said actuating means (420,440,460,550) are breath-actuated, on inhalation at said nozzle (405).

3. A dispensing device according to Claim 1 wherein the indicating element (101) has internal teeth (103) which are engaged by the indexing member (109), the teeth (103) and the engagement portion of the indexing member (109) being inclined with respect to the axis of rotation of the indicating member (101), and the indexing member (109) being resiliently mounted

10. A dispensing device according to Claim 1 wherein a cover (510) for said nozzle (405) of the housing is movably mounted on the housing, and a cam formation (520) on the cover (510) cooperates with the lower end of a depending member (530) associated with said part of the actuating means such that, when the cover is closed, the depending member moves said part to reset the actuating means and thereby to move said indexing member (109) in said axial direction.

11. A dispensing device according to Claim 1 in combination with a drug delivery system in the form of an aerosol dispensing container (25) having a valve capable of being actuated to release a metered amount of the pressurized aerosol contents.

12. A dispensing device according to Claim 1 in combination with a dry powder drug delivery system disposed within said housing and adapted to dispense, when actuated, a dose of powdered medicament into an air flow in said housing created by inhalation at said nozzle (405).

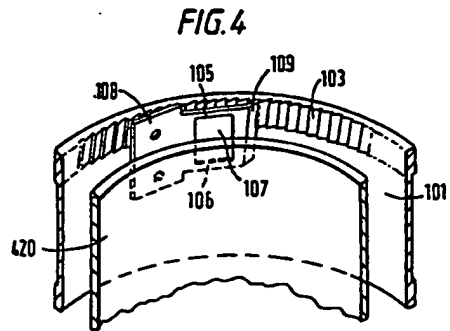
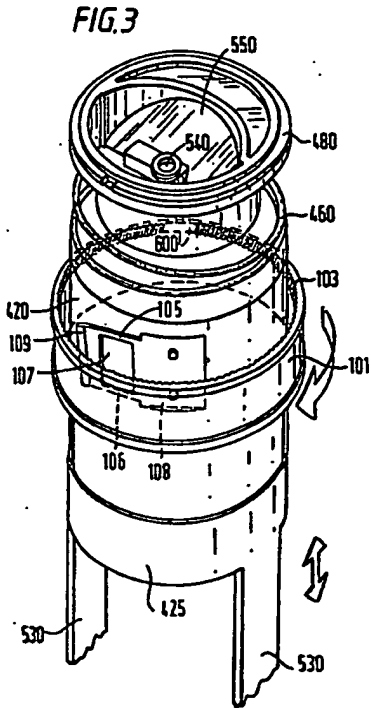
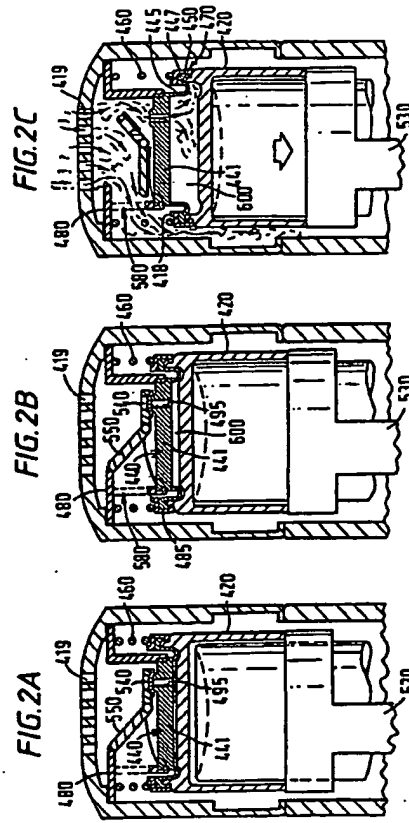
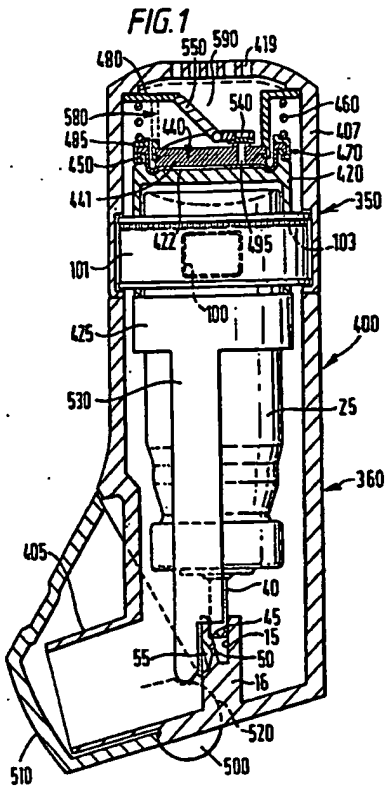

International Application No.

I. CLASSIFICATION OF SUBJECT MATTER (Of several classifications specify only, unless imp.)
 According to International Patent Classification (IPC) or its last Modified Classification and IPC
 Int. Cl. 5 A61M15/00

II. FIELD SEARCHED
 Minimum Documentation Searched?

Classification System	Classification Symbols
Int. Cl. 5	A61M ; G05M

Documentation Searched other than Minimum Documentation as the extent that such documents are indicated in the Field Searched?

III. DOCUMENTS CONSIDERED TO BE RELEVANT?

Category*	Character of Document, with indication, where appropriate, of its relevant passages ¹⁾	Reference to Character No. ²⁾
A	GB, A, 1 317 315 (ENGLISH NUMBERING MACHINES LTD) 15 May 1973 cited in the application see page 2, line 6 - page 3, line 11 see figures 1-3	1,3,11
P,A	WO, A, 9 209 324 (MINNESOTA MINING AND MANUFACTURING COMPANY) 11 June 1992 cited in the application see page 9, line 23 - page 10, line 3 see page 13, line 12 - page 14, line 35 see figures 5,6,9	1,2,4, 10,11

* Special categories of cited documents:
 1) "A" document defining the general state of the art which is not considered to be of particular relevance
 2) "P" document published after the international filing date in a language other than that of the application but which is considered to be of particular relevance
 3) "A" document which may contain data on priority claimed or which is cited to establish the priority of another document
 4) "P" document relating to an oral disclosure, use, exhibition or other event
 5) "A" document published prior to the international filing date but later than the priority date stated

1) "A" document published after the international filing date in a language other than that of the application but which is considered to be of particular relevance
 2) "P" document published after the international filing date in a language other than that of the application but which is considered to be of particular relevance
 3) "A" document which may contain data on priority claimed or which is cited to establish the priority of another document
 4) "P" document relating to an oral disclosure, use, exhibition or other event
 5) "A" document published prior to the international filing date but later than the priority date stated

IV. CERTIFICATION

Date of the Actual Completion of the International Search	Date of Filing of the International Search Report
18 AUGUST 1993	24. 08.93
International Searching Authority	Signature of Authorised Officer
EUROPEAN PATENT OFFICE	SCHOENLEBEN J.

Form PCT/ISA/210 (based upon the 1978 text)

International Application No.

IV. DOCUMENTS CONSIDERED TO BE RELEVANT? (CONTINUED FROM THE SECOND SHEET)

Category*	Character of Document, with indication, where appropriate, of its relevant passages	Reference to Character No.
P,A	WO, A, 9 209 323 (MORTON HEALTHCARE LTD.) 11 June 1992 cited in the application see page 9, line 27 - page 13, line 29 see figures 3-5	1,2,8-11
A	EP, A, 0 269 496 (VALDIS) 1 June 1988 cited in the application see figures 6,7	3
A	WO, A, 8 605 991 (AKTIEBOLGET DRACO) 23 October 1986 see page 2, line 10 - line 17	12

Form PCT/ISA/210 (based upon the 1978 text)

**ANNEX TO THE INTERNATIONAL SEARCH REPORT
 ON INTERNATIONAL PATENT APPLICATION NO. GB 930106A
 SA 74380**

This annex lists the patent family members relating to the present international search report. The members are as contained in the European Patent Office EPO file on The European Patent Office is to be used for those purposes which are expressly given for the purpose of information. 18/08/93

Patent document cited in search report	Publication date	Patent family member(s)	Publication date
GB-A-1317315	16-05-73	None	
WO-A-9209324	11-06-92	AU-A- 9060491	25-06-92
WO-A-9209323	11-06-92	AU-A- 9034091	25-06-92
		CA-A- 2091367	02-06-92
		CH-A- 1062091	24-06-92
EP-A-0269496	01-06-88	FR-A- 2506506	13-05-88
		DE-A- 3774539	19-12-91
WO-A-8605991	23-10-86	SE-B- 448277	09-02-87
		AU-B- 587460	17-08-89
		AU-A- 5771686	05-11-86
		CA-A- 1250503	20-02-89
		EP-A, B 0258238	09-03-88
		JP-T- 62502451	24-09-87
		SE-A- 8501806	13-10-86
		US-A- 4668218	24-05-87